



PARTS BREAKDOWN

HIGH PRESSURE PUMP CART

MODEL: PA-WPF2





PARTS BREAKDOWN

HIGH PRESSURE PUMP CART

MODEL: PA-WPF2

CART ASSEMBLY

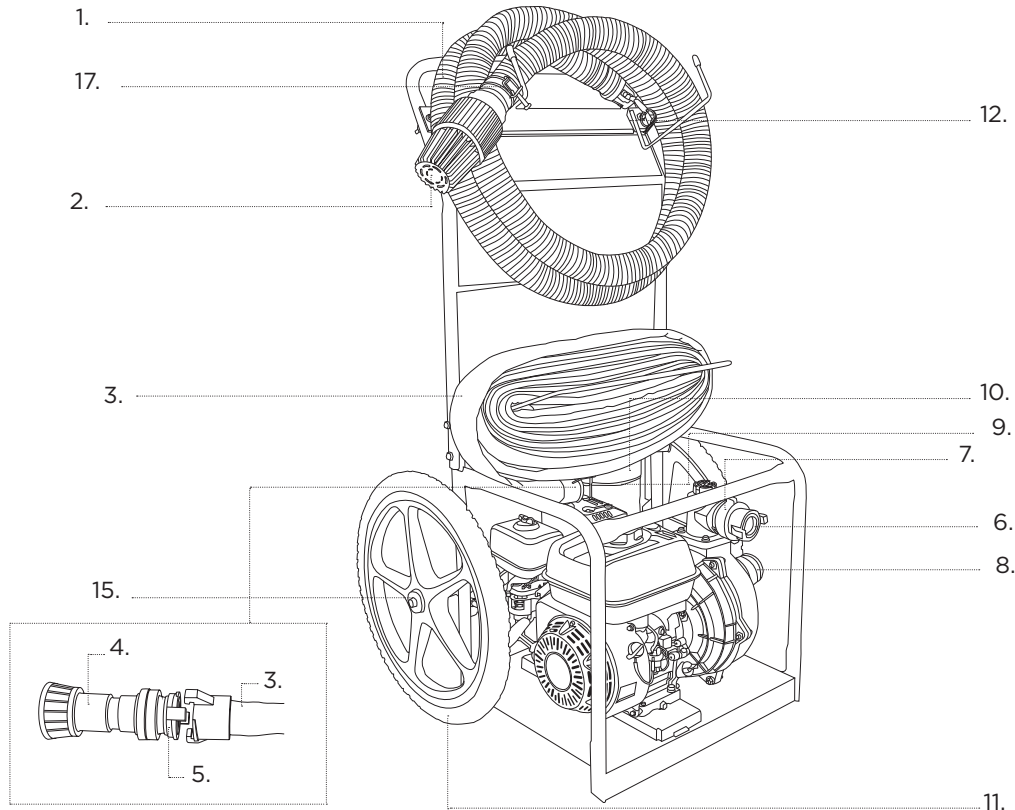

REF #	DESCRIPTION	QTY	PART #
1	Suction Hose with Foot Valve	1	PA-P85400079
2	Foot Valve	1	PA-P50002301
3	Fire Hose, 1.5" x 50'	1	PA-P50015001
4	Spray Nozzle	1	PA-P50015002
5	Adapter, Fire Hose x 1.5" MNPT	1	PA-P50015003
6	Adapter, Fire Hose x 1.5"	1	PA-P50015004
7	Adapter, Reducer, 2" x 1.5"	1	PA-P50015007
8	Adapter, 2" Female NPT	1	PA-P90390200
10	Priming Jug Holder	1	PA-P85601010
11	Fire Cart Wheels	2	PA-P85660123N
15	Wheel Mounting Hardware	2	PA-P90250024BE
12	Suction Hose Hangar	1	PA-P90250010BE



PARTS BREAKDOWN

HIGH PRESSURE PUMP CART

MODEL: PA-WPF2

PUMP ASSEMBLY

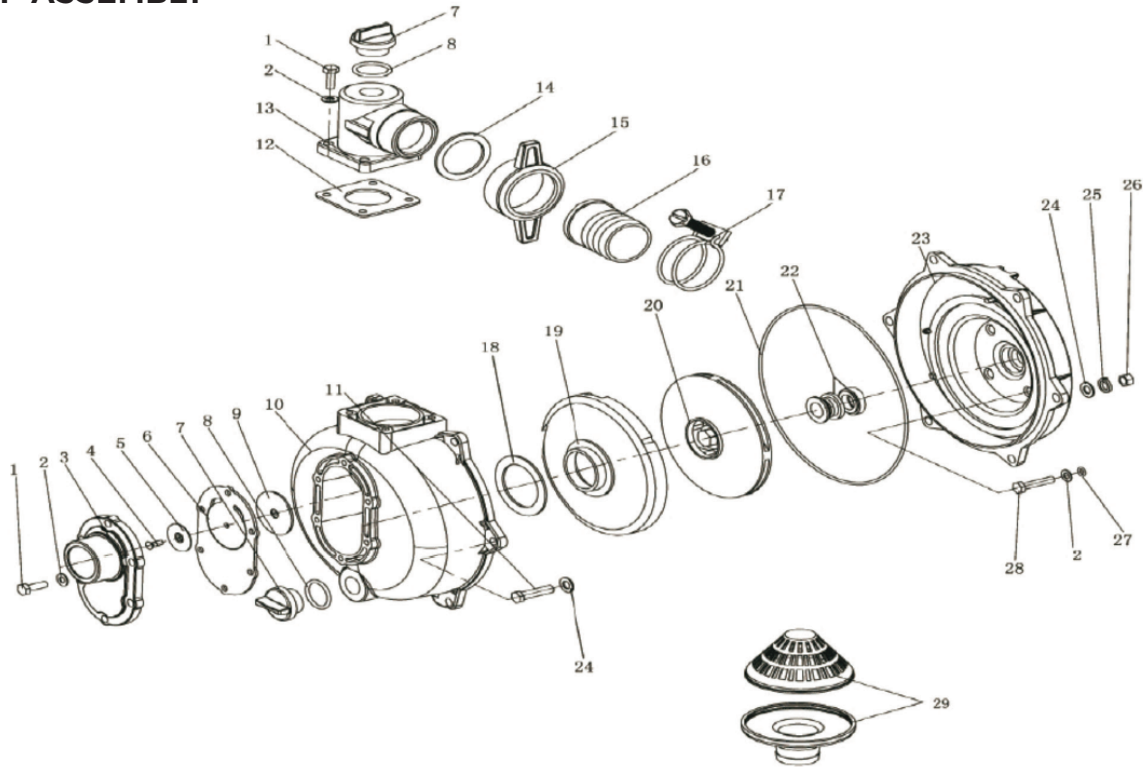

REF #	DESCRIPTION	QTY	PART #
3	Water Inlet	1	PA-P85571142
13	Water Outlet	1	
6	Water Inlet Gasket	1	PA-P85571143F
12	Outlet Gasket	1	
18	Whorl Case Sealing Ring	1	
21	Water Pump Joint Cushion	1	
22	Porcelain Seal	1	
23	Impeller Seal	1	
24	Mechanism Seal Assy	1	
27	Gasket	4	
7	Thread Plug	2	PA-P50002263
8	Screw Plug Washer	2	
10	Pump Body	1	PA-P85571145
19	Whorl Case	1	PA-P85571146F
20	Water Pump Impeller	1	PA-P85571141F
23	Water Pump Joint	1	PA-P85571147F



If you need technical assistance call:

1-800-818-1199

(8:00am - 4:30pm PST, Mon - Fri)